

A PERFORMANCE OF ENERGY STORAGE SYSTEM IS IMPROVED FOR ELECTRIC VEHICLE

¹Neha Kumari, ²Vani Bhargava, ³Dr.Sukhwinder Singh Dhillon,
¹M.Tech Scholar, ²³ Professors

Department of Electrical and Electronics Engineering,
Ajay Kumar Garg Engineering College, Ghaziabad (U.P)
APJ Abdul Kalam Technical University, Lucknow (India)

ABSTRACT

In order to provide long distance endurance and ensure the minimization of a cost function for electric vehicles, a new hybrid energy storage system for electric vehicle is designed in this paper. For the hybrid energy storage system, the paper proposes an optimal control

As a result, the size of battery is reduced, and the power quality of the Energy Storage System is optimized. Finally, the effectiveness of the proposed method is validated by Simulation. A given device may be optimized for one of either energy storage or power delivery, at the sacrifice of the other. A energy storage system attempts to address the storage needs of electric vehicle by combining two of the most popular storage technologies, lithium-ion batteries, for energy capacity and ultra capacitors.

KEYWORDS: AC Voltage Source, Li-ion Battery, Super-Capacitor Energy Storage System.

INTRODUCTION- Energy storage systems (ESS) are gaining more attention in the modern electric grid due to the rapid growth of renewable grid integration. ESSs support the renewable energy producers and also system operators by providing many services such as energy time frame shifting, ancillary features, capacity firming, intermittency handling, transmission congestion relief, and power quality improvements[1][2].

The combination of Li-ion battery and super capacitor leads to a hybridised power supply having superior performance in terms of weight, cost, driving range and lifetime, compared with a regular single battery [3,4]. In this context, there are several kinds of structures for battery–super capacitor hybrid power supply mainly due to the differences in system constitution and energy management strategy. In our case, a parallel connection of battery and super capacitor results in a simple configuration.fig1.

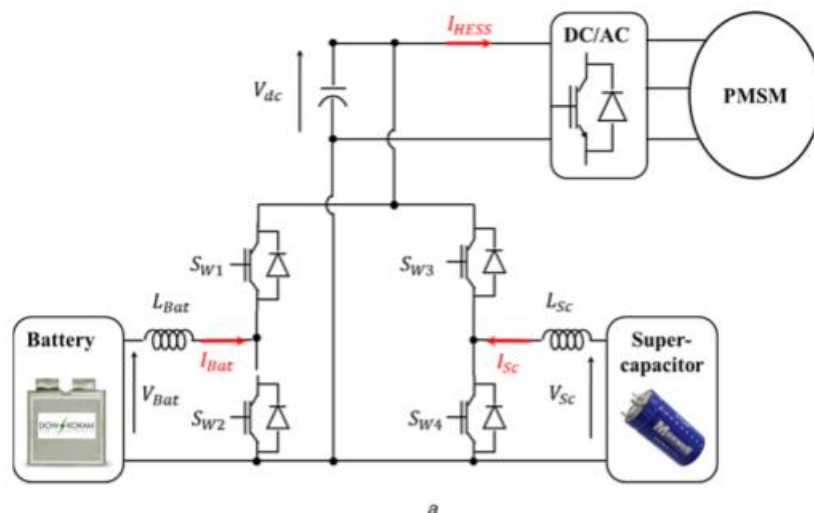

Fig1

This paper proposes an integrated framework for HESS sizing and battery cycle life optimization based on a developed battery cycle life degradation model. It distinguishes itself from existing studies, since it optimally sizes the ESS size/weight under the power and energy requirements and battery cycle life constraint, and adopts a validated battery cycle life estimation model and extends its usage to scenarios under varying current rates and driving profiles for EV applications. In addition, majority of published work on ESS power management uses dynamic programming and control State-of Charge (SoC) of batteries and UCs as state variables for offline optimization. In these studies, the optimization objectives such as fuel economy, ESS energy efficiency, or energy loss are directly controlled by the SoC [5][6].

1. Dc-Dc Converter

A DC-to-DC converter is a device that accepts a DC input voltage produces a DC output voltage. Typically the output produced is at a different voltage level than the input.

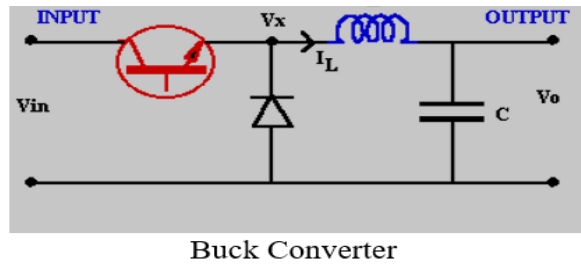
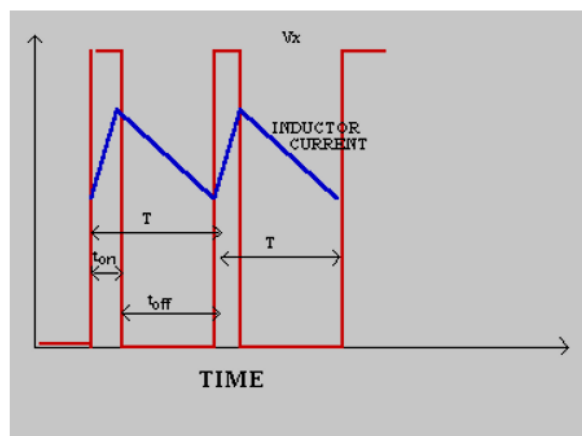

Fig2.

BUCK CONVERTER STEP-DOWN CONVERTER

In this circuit fig(2) the transistor turning ON will put voltage V_{in} on one end of the inductor. This voltage will tend to cause the inductor current to rise. When the transistor is OFF, the current will continue flowing through the inductor but now flowing through the diode. Fig2 (a)



Voltage and current changes

Fig.2 (a)

To analyze the voltages of this circuit let us consider the changes in the inductor current over one cycle. From the relation

$$V_x - V_o = L \frac{di}{dt} \dots\dots\dots (1)$$

$$di = \int_{ON} (V_x - V_o) dt + \int_{OFF} (V_x - V_o) dt \dots\dots\dots (2)$$

$$0 = di = \int_0^{t_{on}} (V_{in} - V_o) dt + \int_{t_{on}}^{t_{on}+t_{off}} (-V_o) dt \dots\dots\dots (3)$$

$$(V_{in} - V_o)t_{on} - V_o t_{off} = 0 \dots\dots\dots (4)$$

$$\frac{V_o}{V_{in}} = \frac{t_{on}}{T} \dots\dots\dots (5)$$

$$D = \frac{t_{on}}{T} \dots\dots\dots (6)$$

BOOST CONVERTER STEP-UP CONVERTER

The schematic in Fig.(3) shows the basic boost converter. This circuit is used when a higher output voltage than input is required.

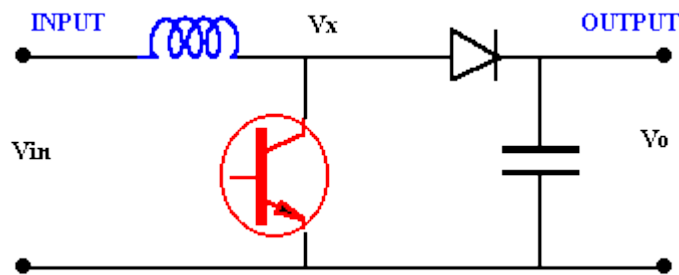

Boost Converter Circuit fig(3)

$$V_{in} t_{on} + (V_{in} - V_o)t_{off} = 0 \dots\dots\dots 1$$

$$\frac{V_o}{V_{in}} = \frac{T}{t_{off}} = \frac{1}{(1-D)} \dots\dots\dots 2$$

$$\frac{I_o}{I_{in}} = (1-D) \dots\dots\dots 3$$

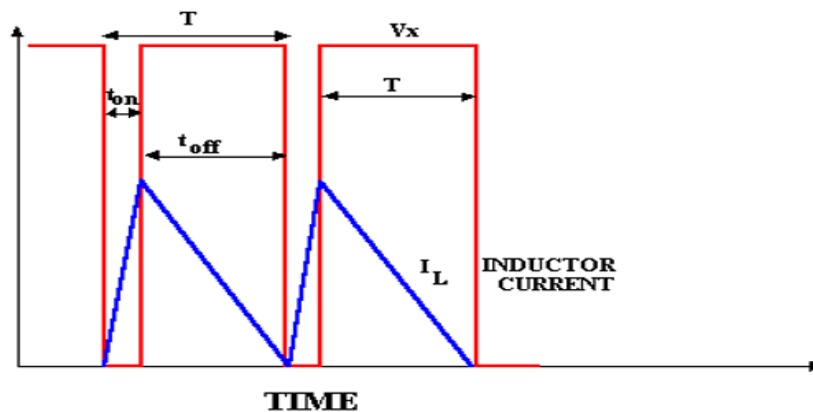

Buck Converter at Boundary

Fig.3 (a)

BATTERY

An electric battery is a device consisting of one or more electrochemical cells with external connections provided to power electrical devices such as flashlights, smart phones, and electric cars. When a battery is supplying electric power, its positive terminal is the cathode and its negative terminal is the anode. The terminal marked negative is the source of electrons that when connected to an external circuit will flow

and deliver energy to an external device. When a battery is connected to an external circuit, electrolytes are able to move as ions within, allowing the chemical reactions to be completed at the separate terminals and so deliver energy to the external circuit. It is the movement of those ions within the battery which allows current to flow out of the battery to perform work. Historically the term "battery" specifically referred to a device composed of multiple cells, however the usage has evolved additionally to include devices composed of a single cell.

Table 1 The operation mode of hybrid energy storage system

Working mode	Power source	Power flow	Operation mode
Parking charging mode	AC power	Battery and super capacitor	Buck
Constant speed mode	Battery	DC	Boost
Acceleration mode	Super capacitor	DC motor	Boost
Braking mode	Braking energy	Battery and super capacitor	Buck
Super-capacitor charging mode	Battery	Super capacitors and DC motors	Boost or buck

LITHIUM ION BATTERY

The battery pack control can produce a smooth supply of the DC motor current. The second-order cut-off frequency of 50Hz Bessel low-pass filter has been applied to reduce output current ripples or avoid instantaneous large changes.

Assuming the converter is lossless, the DC motor current is equal to the battery current, which can be expressed as:

$$\frac{I_{L2}(s)}{D(s)} = \frac{V_{dc} R_{Load} C_{dc} s + 2V_{dc}}{R_{Load} L_2 C_{dc} s^2 + L_2 s + R_{Load} (1-D)^2} \quad (1)$$

$$\frac{V_{dc}(s)}{I_{L2}(s)} = \frac{-L_2 s + R_{Load} (1-D)^2}{R_{Load} C_{dc} (1-D)s + 2(1-D)} \quad (2)$$

$$V_{load} \times I_{load} = V_{batt} \times I_{batt}; I_{batt} = \frac{V_{load} \times I_{load}}{V_{batt}} \quad (3)$$

The reference current of the battery pack is expressed as:

$$I_{batt}^* = \frac{V_{load} \times I_{load}}{V_{batt}} G_{LP}(s) \quad (4)$$

Block Diagram of energy storage system FIG(4)

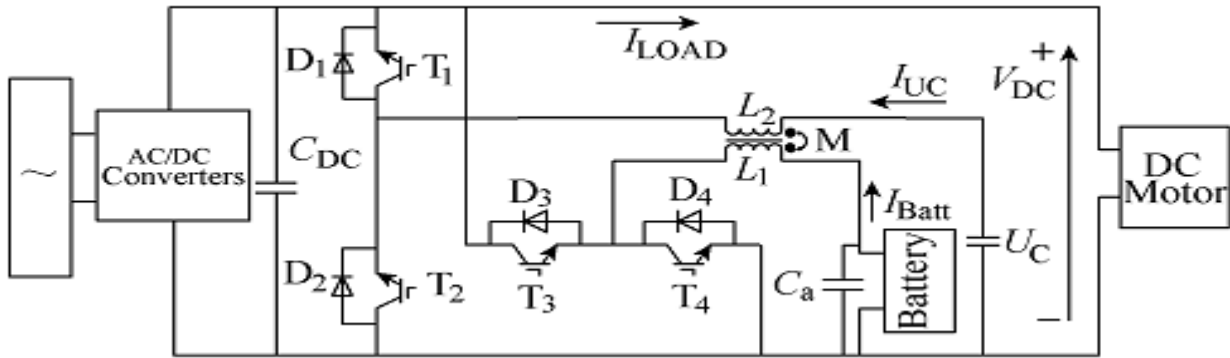

Simulation of the super-capacitor voltage and current controller

In order to ensure enough energy from the super- capacitor, when the SOC of the super-capacitor is below the limit, the super-capacitor charges from the Li-ion battery. Moreover, in the beginning of the driving cycle, a target value of super-capacitor SOC is chosen as the initial value to provide enough energy. An additional control loop based on PI controller, which controls the continuous recharge of super-capacitor from Li-ion battery during the driving phase and also when the electric vehicle is at a standstill, is designed. Fig.4 is a specific block of the additional control loop.

Parameters	Value
$N_{SB} \cdot N_{PB}$	185
$N_{P_sc} \cdot N_{S_sc}$	570
Li-ion battery η_{DOD}	80%
Li-ion battery initial SOC	1
Super-capacitor initial SOC	0.94
Li-ion battery En/(kW·h), P_{max}/W	10, 200
Super-capacitor En/(kW·h), P_{max}/W	0.25, 200

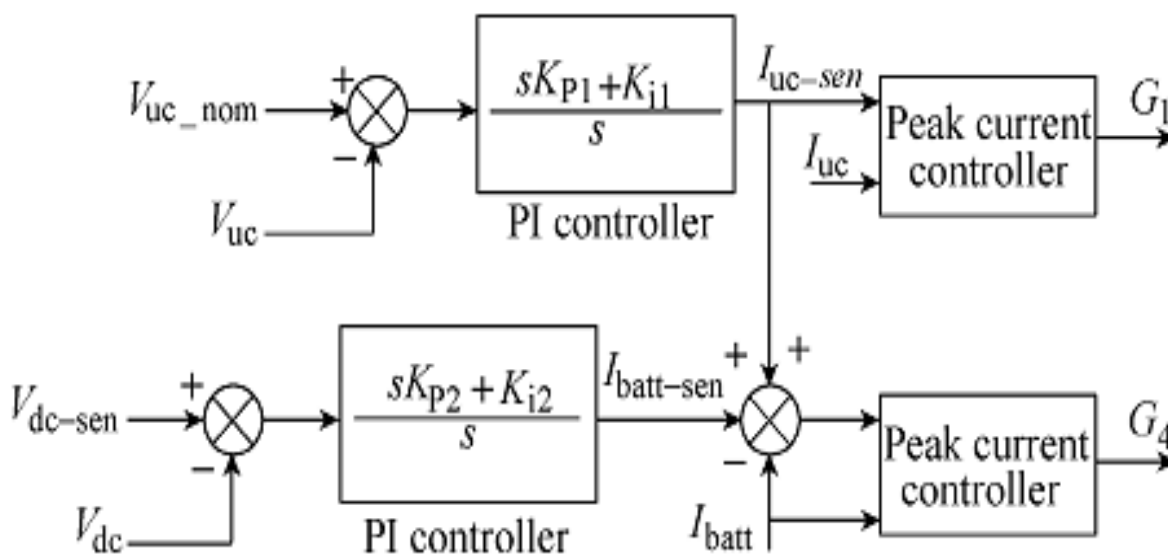

Fig(5)

SIMULATION AND EXPERIMENT OF PROPOSED HESS APPLIED TO ELECTRIC VEHICLES

The proposed HESS takes full advantage of Li-ion batteries and super-capacitors, so that the super-capacitor maintains the ability of power conditioning and improves the overall performance of HESS.

Simulation

The simulation model of the proposed HESS applied to a typical car driving cycle is built on Mat lab/ Simulink to test the dynamic performance of the system

Graph 1. Power of the super capacitor and li-ion battery Power/watt v/s time/sec

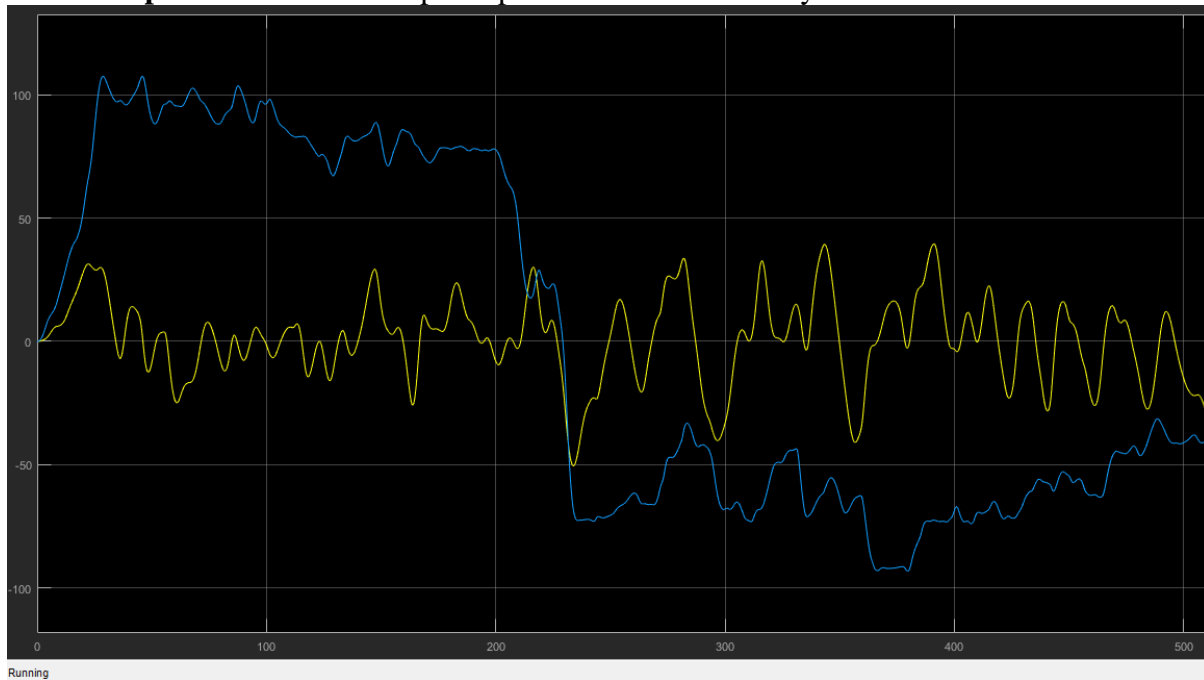

Graph2. Super capacitor current v/s time

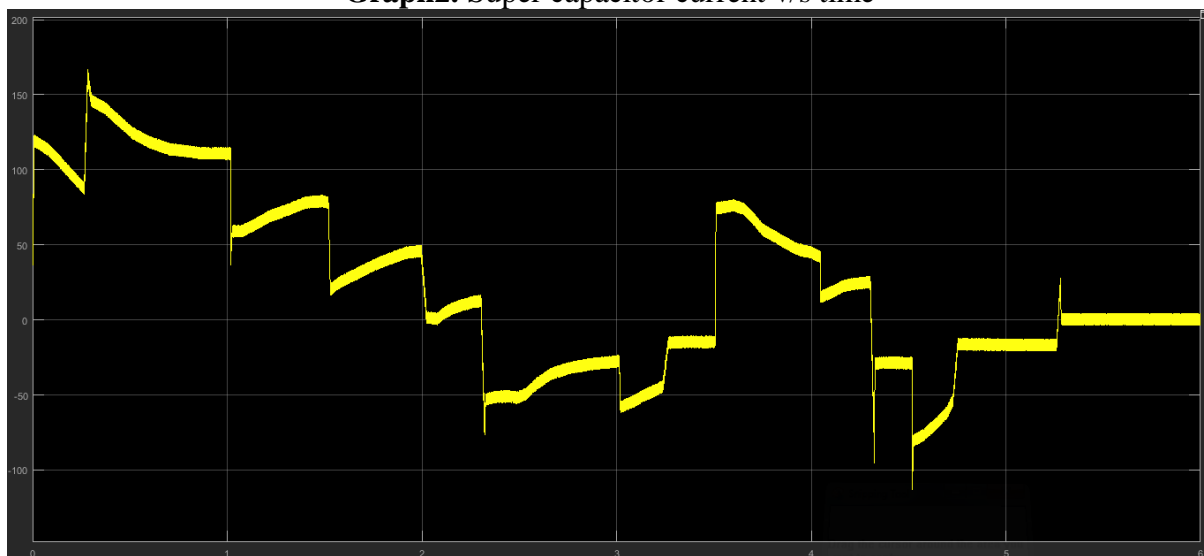

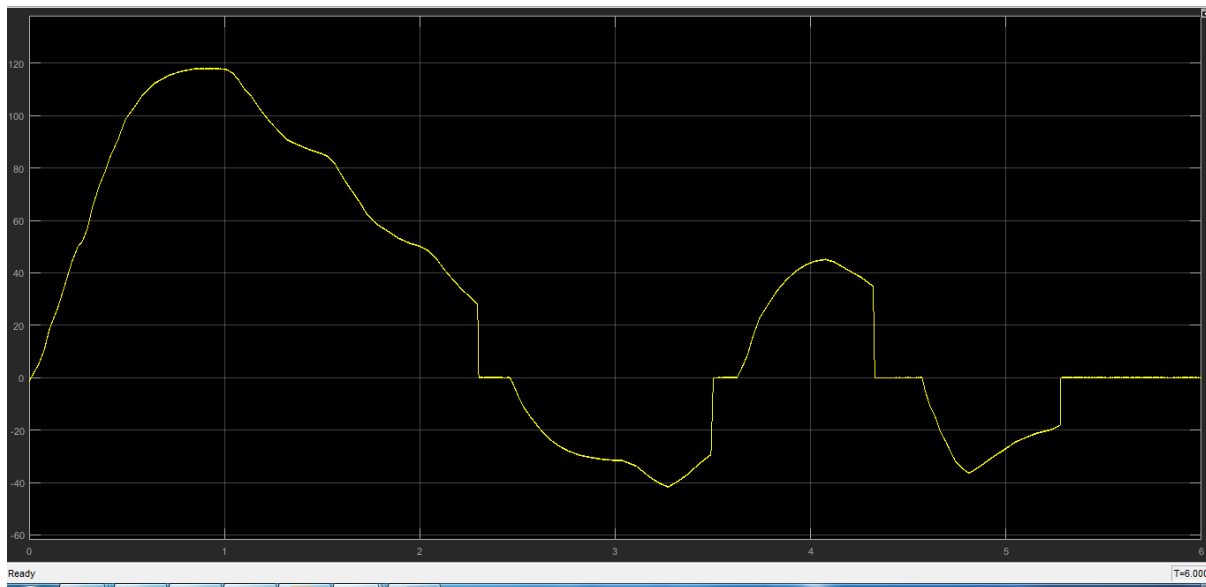
Graph3. Load current v/s time/sec

CONCLUSIONS

In this paper, a new energy storage system for electric vehicles is designed based on a Li-ion battery power dynamic limitation rule-based ESS energy management and a new bi-directional.

REFERENCES

1. P.Kreczanik, P.Venet, A.Hijazi, and G.Clerc, "Study of super capacitor aging and life time estimation according to voltage, temperature, and rms current," *IEEE Trans. Ind. Electron.*, vol. 61, no. 9, pp. 4895–4902, Sep. 2014.
2. G. Graditi, M. Ippolito, E. Telaretti, and G. Zizzo, "An innovative conversion storage systems," *IEEE Trans. Ind. Electron.*, vol. 62, no. 4, pp. 2540–2550, Apr. 2015.
3. Guidi, G., Undeland, T.M., Hori, Y.: 'Effectiveness of super capacitors as power-assist in pure EV using a sodium–nickel chloride battery as main energy storage'. *EVS24 Int. Battery, Hybrid and Fuel Cell Electric Vehicle Symp.*, 2009, [4] Camara, M.B., Gualous, H., Gustin, F., et al.: 'DC/DC converter design for super capacitor and battery power management in hybrid vehicle applications – polynomial control strategy', *IEEE Trans. Ind. Electron.*, 2010, 57, (2), pp. 587–597.
4. D. Karbowski, A. Rousseau, S. Pagerit, and P. Sharer, "Plug-in vehicle control strategy: From global optimization to real time application," in *Proc. 22nd Int. Electric Veh. Symp. (EVS22)*, Yokohama, Japan, 2006, pp. 1–12.
5. S. M. Lukic, S. G. Wirasingha, F. Rodriguez, J. Cao, and A. Emadi, "Power management of an ultra capacitor/battery hybrid energy storage system in an HEV," in *Proc. IEEE Veh. Power Propul. Conf. (VPPC'06)*, Sep. 2006, pp. 1–6.
6. L. Wang, E. G. Collins, and H. Li, "Optimal design and real-time control for energy management in electric vehicles," *IEEE Trans. Veh. Technol.*, vol. 60, no. 4, pp. 1419–1429, May 2011.
7. Zhikang Shuai, Yang Hu, Yelun Peng, Chunming Tu, Z. John Shen, "Dynamic stability analysis of synchronverter-dominated micro grid based on bifurcation theory," *IEEE Transactions on Industrial Electronics*, vol. 64, no. 9, pp. 7467–7477, Sep. 2017.
8. Q. Li, W. Chen, Y. Li, S. Liu, and J. Huang, "Energy management strategy for fuel cell/battery/ultracapacitor hybrid vehicle based on fuzzy logic," *Int. J. Electr. Power Energy Syst.*, vol. 43, no. 1, pp. 514–525, Dec. 2012.
9. Zhikang Shuai, Wen Huang, Chao Shen, Jun Ge, and Z. John Shen, "Characteristics and restraining method of fast transient inrush fault currents in synchronverters," *IEEE Transactions on Industrial Electronics*, vol. 64, no. 9, pp. 7487–7497, Sep. 2017.
10. Castaings, W. Lhomme, R. Trigui, and A. Bouscayrol, "Comparison of energy management strategies of a battery/ super capacitors system for electric vehicle under real-time constraints," *Appl. Energy*, vol. 163, pp. 190–200, 2016.